

## M822 standalone Skinning Machine

### A Unique Approach Ensures:

- Better treatment of raw material
- Better overall yield and fillet quality
- Maximum processing ability and performance
- Optional: Cleaning Roller

The M822 Line of Skinning Machines has Two Separate Skinning Units, with Two Additional Units Optional.

### The Skinning Units in the Machine Can be Replaced Within Five Minutes so That:

- Changes to the processing of different fish species, sizes and conditions can be responded to immediately.
- The skinning machine is always adjusted according to the raw material being processed.
- It is easy to troubleshoot, while ensuring maximum yields in the processing line.
- Maximum processing capacity is ensured and that the raw material is always skinned with the best possible quality and yield.

### The Skinning Units are Delivered in Accordance with the Needs of each Customer

- Allows for the same set-up in all four skinning units, e.g. when processing similar fish species for a long time.
- Possible to select different skinning units for plants processing a greater range of raw material.
- Customers can purchase additional skinning units as needed.

Robust Construction in Combination with Innovative Technical Solutions Results in Stability of Settings and Functional Areas. This Guarantees Maximum Yield as Well as Quality of Fillets.



**Particularly Economical on Board Freezer Vessels and in Fish Processing Plants that Need to Process different Fish Species and Sizes with Maximum Capacity.**

- Maximum durability – Minimum maintenance – Increased Yield and Profitability
- Over 100% higher bearing surface ratio per roller meter • Changeable bearing housing • Effective lubrication access
- Adjustable sweeper roller • Simple and space-saving design • User friendly to maintain and adjust
- Easy to clean, less bacterial growth • Corrosion free / Electropolished

**TakeControl – easy to use operating system**

- Change of settings at the push of a button
- Interconnected with our other PLC controlled processing machines
- Easily accessible maintenance database • Multiple language user interface

**Floor Plan - Dimensions:**

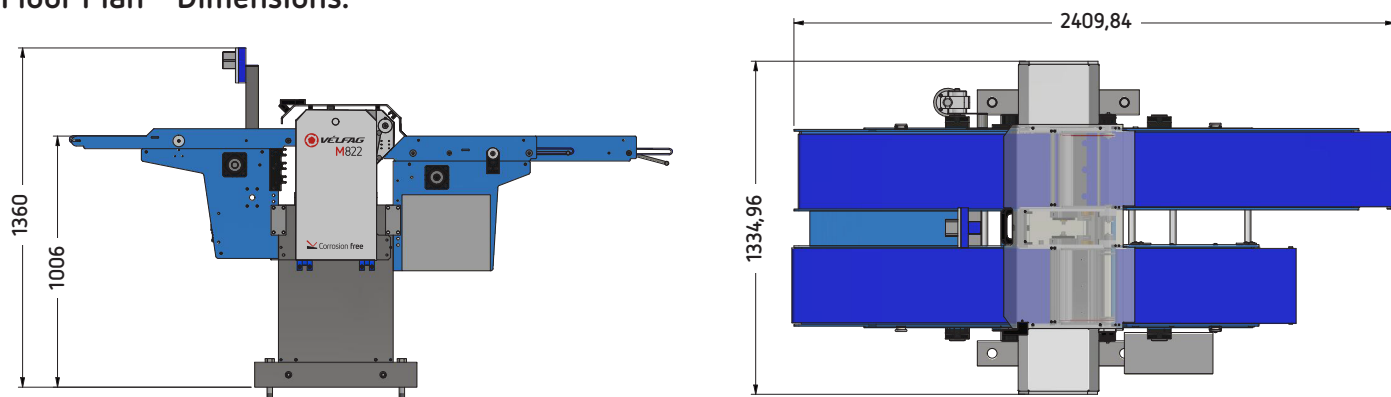

**Technical Data:**

<b>Fish Species:</b>	Whitefish, redfish, flatfish and salmon
<b>Operation:</b>	1 person
<b>Speed:</b>	Adjustable
<b>Working Range</b>	Super small - XXL fillets
<b>Throughput:</b>	Up to 180 fillets / min ( 90 fillets / min pr. lane )
<b>Water Consumption</b>	20 L/min
<b>Cleaning Roller:</b>	4-6L/min
<b>Power Consumption:</b>	1,10 kW / 2,25 kW
<b>Voltage:</b>	400V
<b>Current Requirement:</b>	16A
<b>Weight:</b>	380 kg
<b>Quality of Material:</b>	316 Stainless steel. Electropolished stainless steel. POM plastics. Antibacterial DuPont™ Corian® for stationary surfaces.

**Working Range:**

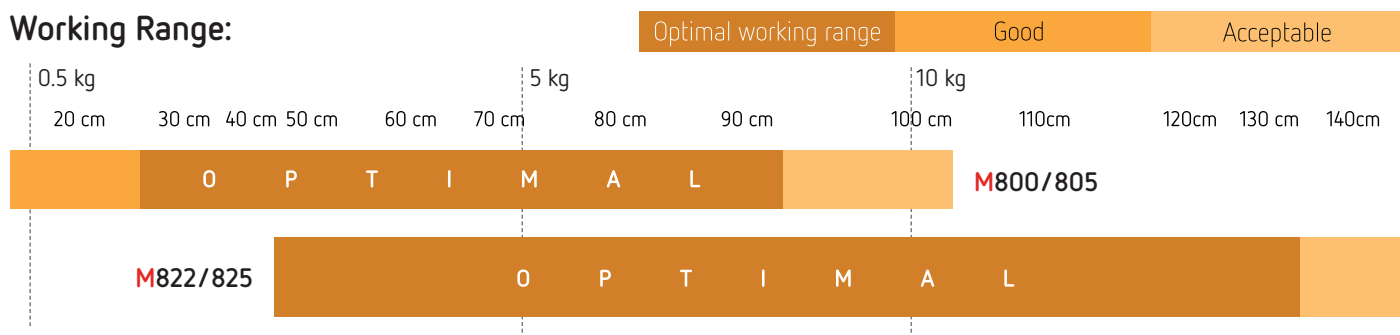

02.2025 design - www.effekt.is